

EPCOS Application Note

Food Processing Industry

Power Quality Solutions



PQS

Application Note

The collection of "PQS Application Notes" is a library with in-depth information on PFC applications, case studies and reference projects. It also serves as a helpdesk for all topics relating to PFC and PQS, is suitable for training purposes and is designed to answer frequently asked questions.

Each issue will focus on a particular application topic, a specific solution or a topic of general interest. The aim is to share the extensive knowledge gained globally by EPCOS PFC experts with regional staff who deal with PFC and PQS. The authors of the PQS Application Notes have extensive experience in the field of PFC and PQS and a professional background as electrical/design engineers or product marketing managers throughout the world.

These PQS Application Notes will be issued from time to time and can be downloaded from the EPCOS Internet under www.epcos.com/pfc

Please contact the EPCOS PM department in Munich if you wish to receive the latest issue of the PQS Application Notes automatically by e-mail. A list with available titles may also be obtained from the PM department in Munich.

Important Notes

Some parts of this publication contain statements about the suitability of our products for certain areas of application. These statements are based on our knowledge of typical requirements that are often placed on our products for a particular customer application. It is incumbent on the customer to check and decide whether a product is suitable for use in a particular application. This Application Note may be changed from time to time without prior notice. Our products are described in detail in our data sheets. The Important Notes (www.epcos.com/ImportantNotes) and the product specific warnings and cautions must be observed. All relevant information is available through our sales offices.

Application Note

Foreword

With the changing lifestyle, a lot of changes occurred in daily routine of human being. The most essential is the food. Considering the time constraint of preparation of food and busy schedule, the services towards food have increased and this created the need of food industry. Now it has become integral part of our life. We get lot of variety of available food and in ready packets or instant cooking packets.

After independence and green revolution the Indian food industry has grown very rapidly and substantiated the footprints in the world with its rising exports to countries all over the world. The reported sale of food industry in India is US\$ 22 billion (132'T Crores INR) in 2014.

Particularly with the sea-shore of 3000 km, the sea-food industry received special attention and has shown significant growth.

The company that is described hereafter is major producer of shrimp (sea-food). This food processing industry has grown from production of about 150 MT in 1994 to 290,000 MT in 2014. The shrimp processing facility is located in the south of India.

With its state-of-the-art processing facilities, lot of investment is done in refining the process to ensure high degree of quality from hatcheries to finished packing. To address the growing need of energy, the company has decided to reduce energy waste and to improve the power quality of existing installation. With the drives the company was also facing the problem associated with harmonics and electronic-card failures in compressor equipment which are very critical. Hence in consultation of M/S LRVi solution has decided to install detuned APFC system and Active harmonic filter made by EPCOS.



The Author
Kedar Gramopadhye

EPCOS India - PQS Product Marketing Department with 12 years in sales and marketing of in electrical and electronic industry. Currently responsible for PQS business in India and is located in Nashik.

Application Note

Contents

Power Quality Solutions at Food Processing Industry in India	5
1. Background	5
2. The company profile and process	5
- Manufacturing process	5
3. The project.....	5
- Power factor regulation and excessive harmonics	5
- Main objectives of PF and harmonic limits	5
4. Electrical layout of the plant	5
- Single line diagram	6
- Details of transformers and load	6
5. Sizing of APFC panels and active harmonic filters.....	7
- Configuration of detuned APFC panel.....	7
- Active harmonic filter and its configuration.....	7
6. Post installation measurements.....	7
- Results	7
- Power factor improvement, current harmonics and voltage harmonics.....	7
7. Features and some key advantages of components from EPCOS.....	8
- Rack module	8
- APFC panel with rack module	8
- Phantom load testing facility	9
- Active harmonic filter	9
8. Benefits	10
9. Conclusion and remarks	10
10. Standards.....	11

Application Note

Solution in Food Processing Industry

Power Quality Solution in Food Processing Industry in India

1. Background

A new era of seafood business started end of 1990 in the south of India in the small village Iskapally (Andhra Pradesh) with the foundation of a new company for seafood-processing. Especially a new type of aquatic species called *Litopenaeus vannamei* – white shrimp or white leg shrimp – has become famous as an excellent sea food not only in India, but all around the globe.



Shrimp selection and dish with delicious shrimp

2. The company profile and process

The company has become state-of-the-art in terms of processing facility and is exporting a wide range of products from raw shrimp to boiled shrimp with its own famous brand name.

The main processes involved in manufacturing of the products are briefly described. The shrimp seeds are artificially hatched in the hatcheries and laid into farms. The full grown shrimps are then collected, washed and cleaned. After they are deheaded, they are put into artificial grinding machine. The outer layer is peeled off and the shrimps are getting deep frozen in special IQF machines. After quality testing, the finished product is packed into special packing and ready to be shipped.

Due to the highly automated processes in the plant, the company management was worried about the power quality. The pollution of the grid by harmonics and lagging power factor led to the decision to call in a PQS-specialist. The task of PQ-consultant Mr. L Ravichandran from M/S LRVI Solutions and M/S EPCOS was to solve the problem.

3. The project

Power factor regulation and harmonics mitigation

Due to lagging power factor and higher harmonic content there were several unreliable operations of compressor systems driven by VFDs (variable frequency drives). Also reduction of production output has been observed, leading to downtime. In addition, the reduction of idle - reactive - power would help to increase the energy efficiency. In addition to these facts, regulatory electricity authority will be tightening the norms towards power factor improvement and reduction of the total harmonic content in the grid.

The company management was convinced that apart from improvement of power factor it was essential to install the active harmonic filter for mitigation of harmonics.

The main *objectives* decided jointly with the company management, the technical consultant M/S LRVI Solutions and M/S EPCOS India Private Ltd. are mentioned as:

- Improvement of power factor to 0.99
- Reduction of total harmonic distortion (THD-I) level < 7%
- Overall improvement of power quality

4. The electrical layout of the plant

Details of transformer and Load:

Type of load	Compressors, pumps and conveyors driven by VFD; IQF machine, refrigeration, lighting
kW installed	1854 kW
System voltage	415 V
Frequency	50 Hz
Fault level	50 kA

Transformer data:

Primary voltage	33 kV
Secondary voltage	433 V
Configuration	ONAN (DYN11)
Rating	2000 kVA
Impedance	5%

All feeder MCCBs are connected through main ACB 3200, 415 V, 50 kA EDO type.

The complete summary of readings of electrical PQ parameters, harmonic content and measurement is described further.

Application Note

Solution in Food Processing Industry

Single line diagram and details

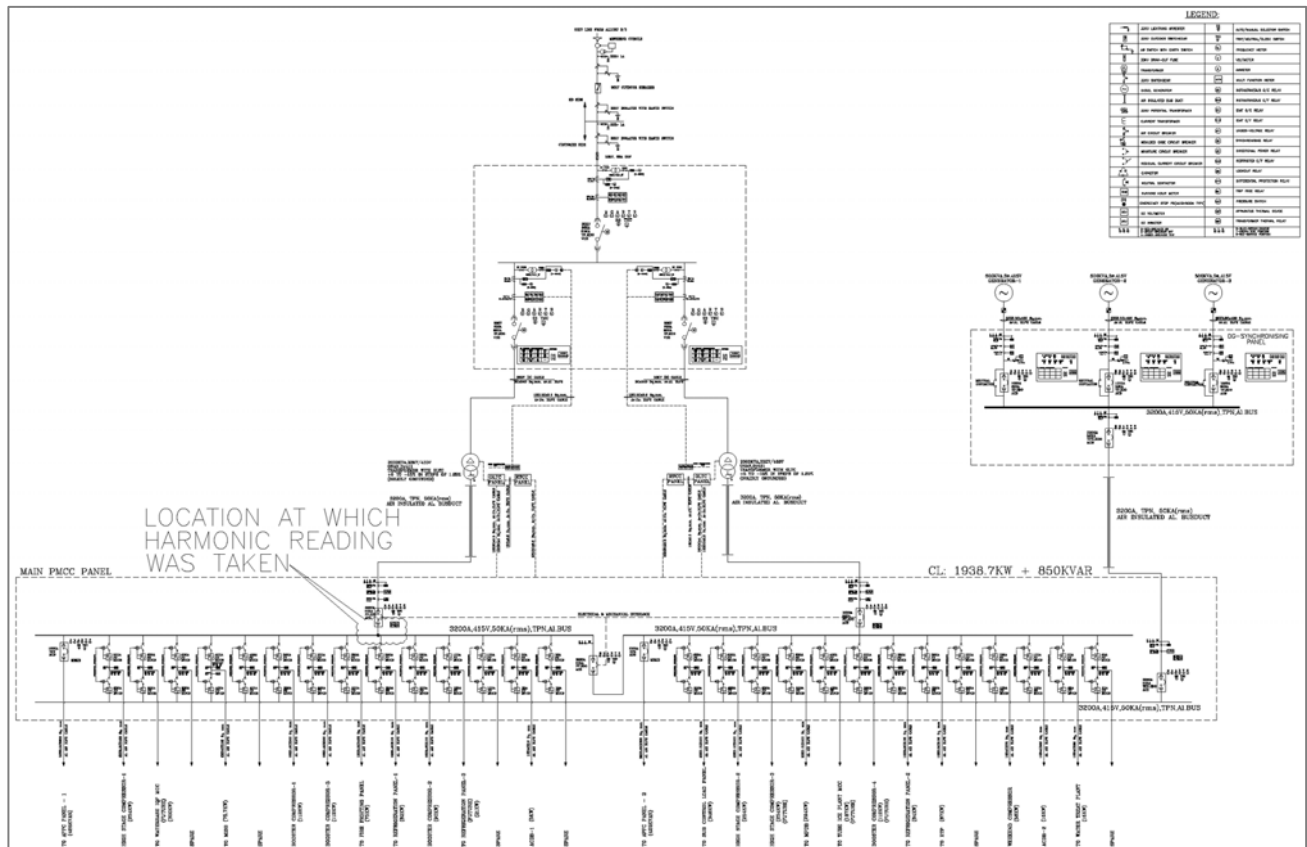

Pre-installation measurement details at the point of measurement

S.NO	Description	Transformer O/G	
		Min	Max
1	FREQUENCY (HZ)	49.86	50
2	VOLTAGE	394.3	412.8
3	VOLTAGE THD%	3.1	5.6
4	CURRENT	896	1311.7
5	CURRENT THD%	20.2	24.9
6	KW	589	830.20
7	KVAR	233.47	307.14
8	KVA	634	885.22
9	PF	0.93	0.94
10	Current Harmonics		
a	3rd	0.3	6.1
b	5th	18.5	23
c	7th	3.50	6.2
d	9th	0.1	1.9
e	11th	3.5	4.8
f	13th	1.6	2.3

S.NO	Description	Transformer O/G	
		Min	Max
11	Voltage Harmonics		
a	3rd	0	0.4
b	5th	2.2	4.6
c	7th	1.1	1.6
d	9th	0	0.5
e	11th	1	1.8
f	13th	0.6	1.2

Application Note

Solution in Food Processing Industry

5. Sizing of APFC panels and active harmonic filter (hybrid system)

Basis of sizing of detuned APFC panel and active harmonic filter

Detuned Power Factor Correction panel: Based on the readings and considering the unity target power factor, the reactive power requirement is seen between 233 to 307 kvar. Hence a size of 300 kvar at rated voltage 415 V and frequency 50 Hz is chosen for correction of displacement power factor.

Upon observations of load variations which are in the range of 10%, a suitable resolution of 25 kvar is chosen to address the compensation with load variation.

The total configuration of detuned power factor correction panel is:

Rated output	300 kvar
Rated voltage	415 V +/- 10%
Step size	25 kvar x 4 + 50 kvar x 4
No. of steps	8
Switching	Contacturised
Capacitor	MKK Type 525 V
Reactor	7% detuned
Incomer	MCCB 630 Amp
Outgoing	MCCB – 10 kA
Controller	BR5000 series for 3-phase sensing
Panel Protection	IP42

Active Harmonic Filter

Upon checking with the distortion power factor, minimum and maximum THD variations, the harmonic filtering requirement lies in between 154 amps to 210 amps.

Considering the target of THD < 7% a suitable size of 180 amps is chosen.

The configuration of active harmonic filter is as below:

Rated Voltage	415 V +/- 10%
Configuration	3-phase – 4 wire
Phase compensation current	180 A
Construction	Floor mounted
Cable entry	Bottom
Compensation	Up to 50 th harmonic



Pre-commissioning site harmonic readings

6. Post installation measurements

After installation and commissioning of detuned PFC panel and active harmonic filters at the site, the post-measurement is conducted again.

The results observed were satisfactory.



Post-commissioning site harmonic readings

Power factor

The observed target power factor is unity and beyond target set of 0.99

Current harmonics

The total current harmonic distortion is reduced from 24% to 6%. The target set was 7%

Voltage harmonics

The corresponding voltage harmonics are reduced from 4.5% to 1.5%

The company management expressed their satisfaction with these achieved results and values.

Application Note

Solution in Food Processing Industry

7. Features and some key advantages of components from EPCOS

Considering the requirement of the customer the PQS-division of EPCOS offered two products to form a hybrid power factor correction and harmonic mitigation system

- Automatic detuned PFC system
- Active harmonic filter

The APFC system was offered with modular rack type concept. This is a highly sophisticated *capacitor rack module* which

- ensures appropriate selection of capacitor and detuned filter reactor
- compactness
- appropriate electrical and mechanical clearances
- modularity
- instantaneous replenishment



Rack module



APFC panel construction with rack module

Application Note

Solution in Food Processing Industry



Phantom load testing facility of APFC panel

The unique features of proposed Active Harmonic Filters are as below:

- Modular design
- Ultrafast reaction time < 21us
- Harmonic compensation up to 50th order
- Touchscreen display and programming
- Load balancing and grid resonance protection
- Selective drive control algorithm and 3 level topology



Application Note

Solution in Food Processing Industry

8. Benefits

The usage of detuned APFC panel and active harmonic filter from EPCOS as a hybrid system offer a broad and reliable range of benefits:

- Improvement of power quality and stability of the voltage
- Avoidance of overheating of transformers, generators and rotating equipment means extended life
- Avoidance of unreliable operation of electronic equipment
- Less machine downtime and increased productivity
- Due to reduction of energy waste the energy efficiency increases
- In case of typical heavy duty applications like automotive (welding) or furnaces, the end product quality is increased
- The modular concept means a “fit-for-future-device”, i.e. the demand in future can also be met
- No detailed analysis is required. This means a significant saving of time and money
- Reduction in CO₂ emission when implied with DG set

The concept of a hybrid system consisting of a detuned PF-system and an active harmonic filter can be widely can be of benefit in multiple industries and applications: *UPS, datacenters, semiconductor production, photovoltaics, automotive industry, plastic industry, office buildings, shopping malls, hospitals and much more.*

9. Conclusions and remarks

By installing a detuned APFC system and active harmonic filter, the target $\cos-\phi$ value 0.99, current THD < 7% and voltage THD < 1.6% in the customer facilities have been achieved along with improved power quality. Further side effects:

- Overall heating and losses in cables. Generally these effects are proportional to square of frequency. Due to reduction of higher order harmonic content, cable losses can be significantly reduced
- With the improved power quality, the downtime in critical process will be reduced
- Extended service life of operating machines and equipment
- Due to reduction in losses overall reduction of energy bill

The company management expressed their satisfaction to the consultant M/S LRVI solutions and M/S EPCOS India for the tailor-made power quality solution for the process industry.



The hybrid PFC solution installation at site (left side detuned PFC system, right side Active Harmonic Filter)

Application Note

Solution in Food Processing Industry

10. Standards

The recommendations and proposals stated in this Application Note are based (amongst others) on several international standards for PFC capacitors, LV switchgear design and electrical systems:

- IEC61000-4: Electromagnetic Compatibility Part – 4
- IEC60146: Semiconductor Converters- General requirements of Line commutated Convertors
- IEC61921: Power Capacitors LV PFC banks
- DIN EN61921: Power capacitors – Low voltage Power Factor Correction
- EN 55011 Class-A: Electromagnetic Disturbance Characteristics-Limits and Method of measurement
- Engineering Recommendation G5/4: Planning levels for harmonic voltage distortion and the connection of non-linear equipment to transmission systems and distribution networks in the United Kingdom
- IEEE Standard 519-1992: IEEE Recommended practices and requirements for harmonic control in electrical power systems
- IEC60439-1/2/3: Low-voltage switchgear and control gear assemblies
- The specifications in the standards and manufacturers' data sheets should always be observed.

Published by
EPCOS AG
CAP FILM P PM PFC
P.O. Box 80 17 09
D-81617 Munich/Germany